

# MONITOR MOUNT SELECT PLUS

For 1 or 2 monitors

max. 32"

Alu



Ergonomic work

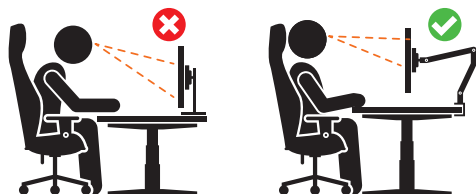

Completely flexible positioning of the monitor due to continuously adjustable arm



With 2 fixing options





For 1 monitor  
# 5096



For 2 monitors  
# 5097

- Mounting with table clamp or table feed-through for table tops of 10–50 mm thickness



- Monitor tilt  
+90° to -90°



- Monitor panning  
+90° to -90°

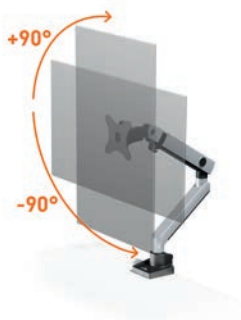

- Monitor rotation  
+90° to -90°

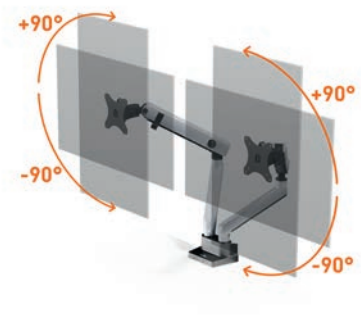

## Monitor mount with flexible arm for 1 or 2 monitors

- For standard monitors up to 32" and 8 kg (each)
- Flexible use with desk sharing or height-adjustable desks
- Removable VESA mount (75×75 mm or 100×100 mm) for easy mounting
- Concealed cable routing to prevent cable breakage
- Sustainable packaging from recycled material

Product	Item no.	Colour	Packaging
MONITOR MOUNT SELECT PLUS for 1 monitor	5096	23 silver	1 piece
MONITOR MOUNT SELECT PLUS for 2 monitors	5097	23 silver	1 piece

# 5097 Monitor Halterung SELECT für mit Arm für 2 Monitore, Tischdurchführung  
 Monitor mount SELECT with arm for 2 screens, through-desk

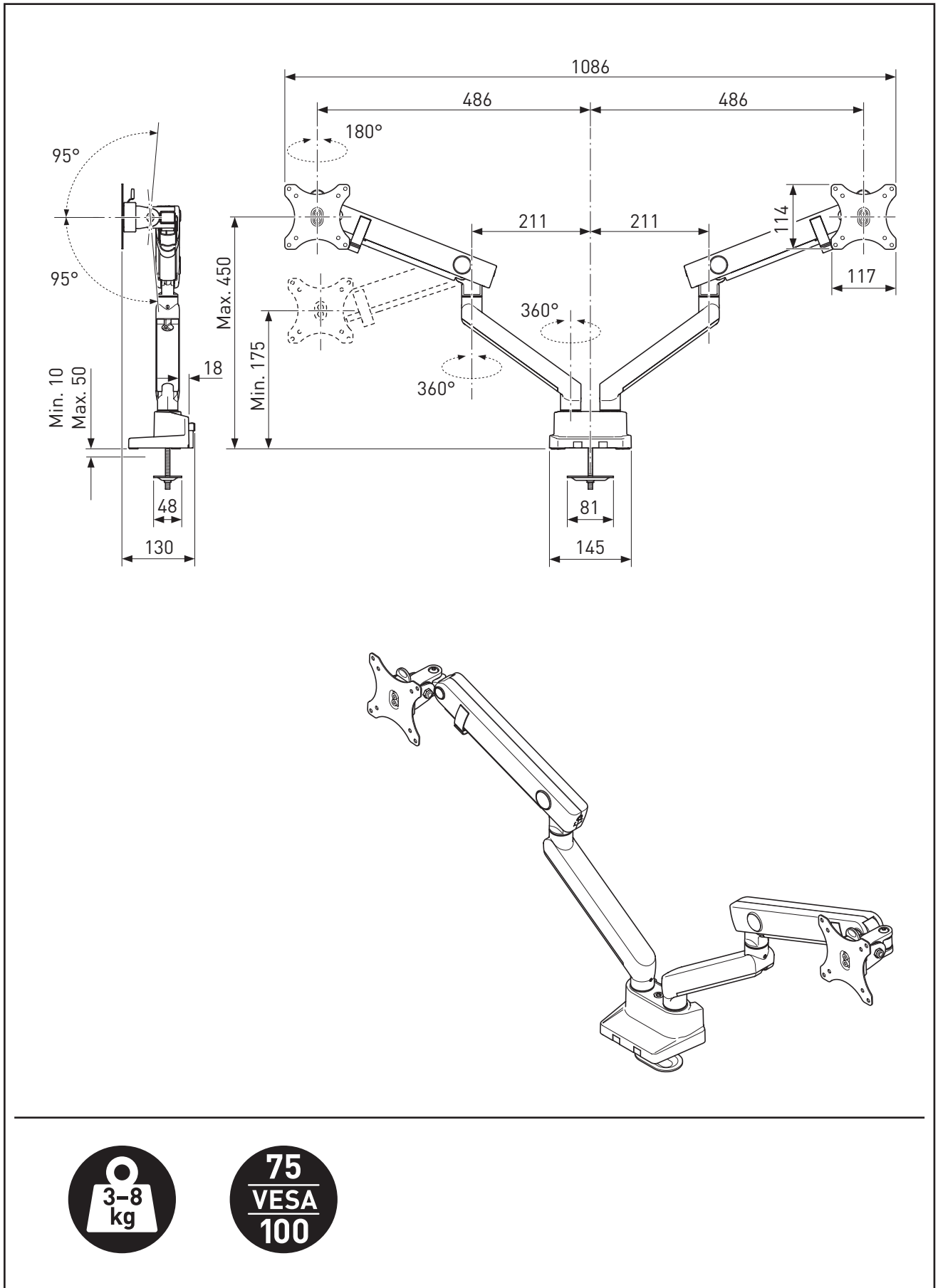

# 5097 Monitor Halterung SELECT für mit Arm für 2 Monitore, Tischbefestigung  
 Monitor mount SELECT with arm for 2 screens, desk mount

